

An Employee Owned Company

WHAT IS MECO'S EA TYPE-2 SEAL?

The MECO EA Type-2 model is the best choice in many sealing applications for low to moderate shaft speeds on small to very large shaft diameters. The EA Type-2 uses full contact, soft face mechanical shaft sealing technology, sized for OEM and custom in-house process equipment. The EA Type-2 model provides the superior performance,

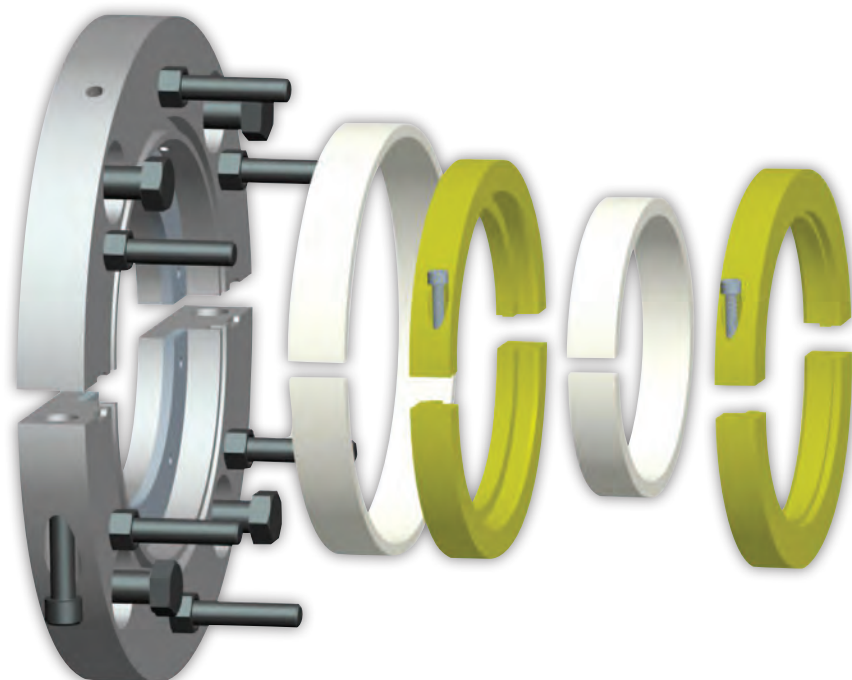

durability and quality of workmanship that are hallmarks of MECO's many other highly-regarded seals. MECO's first rate customer service is provided for each EA Type-2 seal sold.

WHEN ARE EA TYPE-2 SEALS THE BEST OPTION?

The MECO EA Type-2 seal model is ideal for large solvent extractors, pressurized conveyors, holding tanks or similar rotating equipment. Fitment for some blenders, dryers & sigma mixers is also possible. Common industries that use the seal are plastics, oilseed processors, chemicals, carbon anodes, metals, pharmaceuticals and food processors. The EA Type-2 seal model is typically used on horizontal, inclined or vertical shafts and configured for a fully split installation. They are frequently used on rotating shafts where an inert gas barrier in the seal chamber is beneficial.

The seal is appropriate for vacuum service and steady-state applications with infrequent thermal expansion or pressure changes. The seal is adjustable without having to empty the process material. For applications with frequent thermal cycles, pressure cycles and/or aggressive chemicals, the MECO Model EP Type 3 seal is a better match for those challenges.

MECO ENGINEERED SHAFT SEALS



216 Bay Point Road, Georgetown ME 04548 USA
Phone 1 207 371 2210 • Toll-free in North America 1 800 526 8800 • Fax 1 207 371 2169
www.mecoseal.com • Email sales@mecoseal.com
© 2012 Woodex Bearing Company, Inc. All rights reserved

MECO and its distributors work with clients to custom-design seals tailored to each individual need.

HOW DOES THE EA TYPE-2 SEAL MODEL WORK?

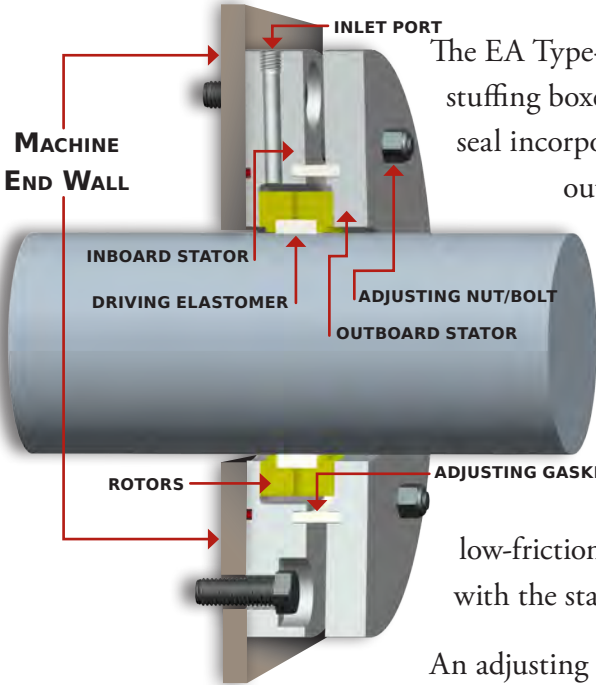

The EA Type-2 seal model replaces standard stuffing boxes & packing glands. The seal incorporates separate inboard and outboard stator housings acting as the stationary seal faces.

Between the stators is a rotating seal face assembly, consisting of two replaceable rotors and a drive elastomer. The stators are drawn together to compress the two seal

rotors against a central driving elastomer. The drive elastomer and rotors interlock to the shaft, forming an air and watertight seal. The low-friction rotating seal faces are at right angles to the shaft and in full contact with the stationary seal faces.

An adjusting gasket permits the distance between the two stator housings to be varied, while containing a barrier fluid within the seal. The EA Type-2 seal cavity is charged with low-pressure air or an inert gas, which acts as a barrier fluid to provide pneumatic seal face loading. This is a simple and effective way to check installation integrity and monitor seal performance. The EA Type-2 seals are manufactured to exacting standards, which ensure parallelism and flatness to maximize product containment and minimize barrier gas consumption.

HOW IS THE EA TYPE-2 MAINTAINED?

The MECO EA Type-2 seal model uses the barrier fluid to pneumatically load the rotating seal faces and as a diagnostic tool. A pressure regulator is included with the seal to set inlet seal cavity pressure. A pressure gage is attached to the inboard stator to monitor seal cavity pressure. Assembly bolts or studs link the two stators. By controlling the distance between the stators while monitoring seal cavity pressure, seal face loading is generated. Over time the pressure will gradually reduce as the sacrificial rotors wear. Using the assembly bolts to re-position the outboard stator resets the rotating seal faces and increases the pressure in the seal cavity. Once the seal cavity pressure is no longer able to be maintained, the rotors and driving elastomer may be replaced with fully split components.



MECO EA TYPE-2A FOR AN EXTRACTOR WITH A 17.5"/445MM SHAFT

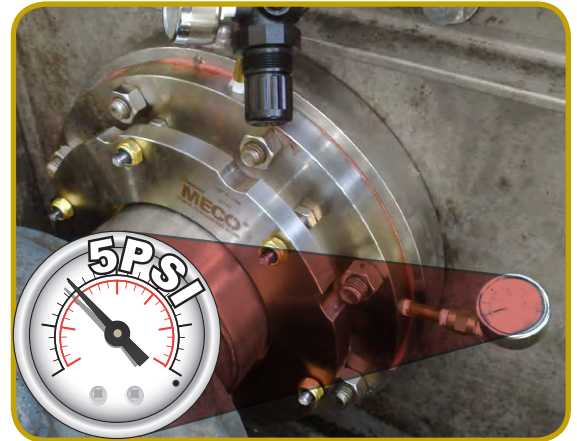

MECO EA TYPE-2S ON A SOY EXTRACTOR WITH A 6.3"/160MM SHAFT

EA Type-2 MODEL TYPICAL DIMENSIONS

WHAT SIZES ARE AVAILABLE?

The MECO EA Type-2 seal model is custom designed and built to order. Typical assemblies are fully split. Shaft diameters range from 1" (25mm) to 20" (500mm) and include all sizes in between. Having extra axial space is always helpful for the installer. Dimensions will vary according to each application, but typical dimensions are shown in the illustration on the back page. They are readily designed to fit most mounting arrangements specified by equipment OEMs, and are designer-friendly, to interface with customized, in-house process equipment requirements. Seals can be built either to S.A.E or metric dimensions.



EA TYPE-2S SEAL ON A POLYMER DRYER WITH A 12.4"/315MM SHAFT



EA TYPE-2S SEAL ON A CONVEYOR WITH A 3"/75MM SHAFT

WHAT CONSTRUCTION IS AVAILABLE?

The MECO EA Type-2 seal's rugged components are designed for long life. Two different housing/stator combinations are available. The EA Type-2A, consists of aluminum housings with replaceable 300 series stainless steel stators attached. The EA Type-2S uses integral 300 series stainless steel stators. Hardened stainless steel is also an option for both stator configurations.

Two common rotor seal face options are MECO 3000, a high performance, bearing grade, polymer filled PTFE with FDA approval, or glass-filled ptf. The different elastomer options available are Silicone, Viton, EPDM and Nitrile and all have an FDA compliant option.

Since Woodex's MECO Seal division manufactures many custom shaft seals, we have the capability to fabricate from any material required.



EA TYPE-2A SEALS FOR HIGH-TEMPERATURE CARBON AND PITCH APPLICATION WITH A 7.5"/190MM SHAFT

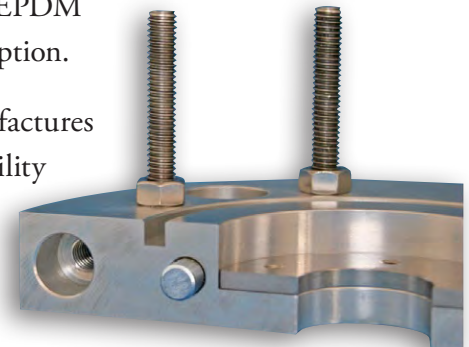

EA TYPE-2A SEAL

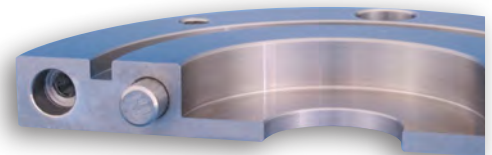

EA TYPE-2S SEAL

www.mecoseal.com

MECO EA Type-2

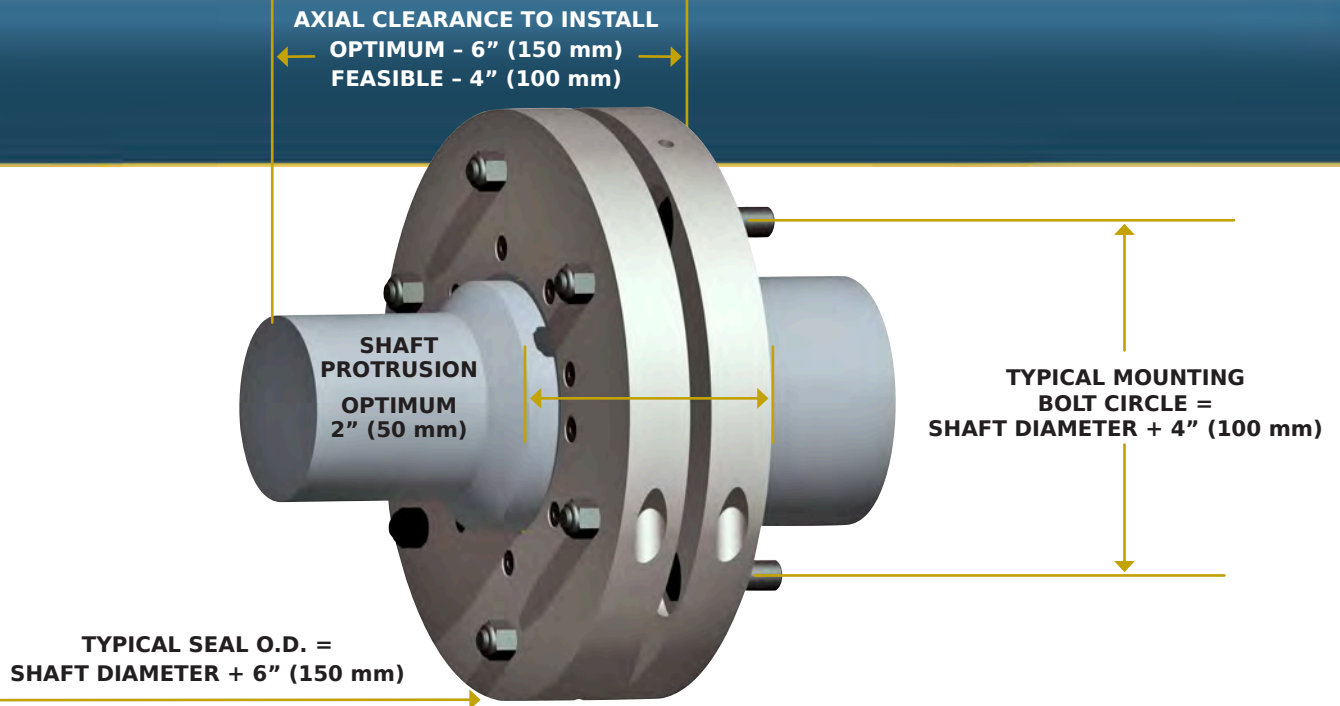

Mechanical Capabilities

Temperature	0° to 500° F (-18° to 260° C) <7" (180mm) shafts 0° to 300° F (-18° to 150° C) >7" (180mm) shafts
Pressure	Vacuum to 20 psig (135 kPa)
Shaft Speed	Up to 250 RPM <7" (180mm) shafts Up to 200 RPM >7" (180mm) shafts
T.I.R. Runout	1/4" (6mm) standard; greater runout can be accommodated
Repeated Axial Shaft Motion	1/128" (0.2mm)
Thermal Shaft Growth	Limits set per application

Results may vary with operating conditions - please call for discussion.



MECO's design staff or your local distributor can help tailor the EA to your individual needs.

Below are a few examples of other **MECO** seal models.



Split OFS Model

- Top and Side Entry
- Solvents
- Purge Free



AH Model

- Blenders
- Screw Conveyors
- Tight Spaces



MP Model

- Air locks
- Rotary Feeders



HB Model

- Standard Seals for C.E.M.A. and Metric Screw Conveyors

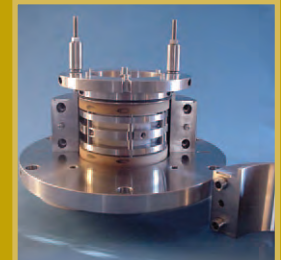

EP Model

- Reactor Vessels
- Dryers
- Extruders

Distributed by:



All MECO Seals

