

An Employee Owned Company

### WHAT IS MECO'S OFS TYPE-1 SEAL?

The MECO OFS Type-1 seal is frequently the best, fully-split seal for vacuum, low pressure, and abrasive applications. The design tolerates both runout and thermal growth at moderate speeds. The OFS Type-1 places a single, hardened, stainless steel rotary seal face, spring-loaded against a single, bearing-grade, polymeric stationary seal face. The seal does not require a barrier fluid. A wide selection of materials are available, allowing service in diverse processes. The fully-split seal is custom-designed for existing process equipment or is tailored to OEM or end-users wishes.

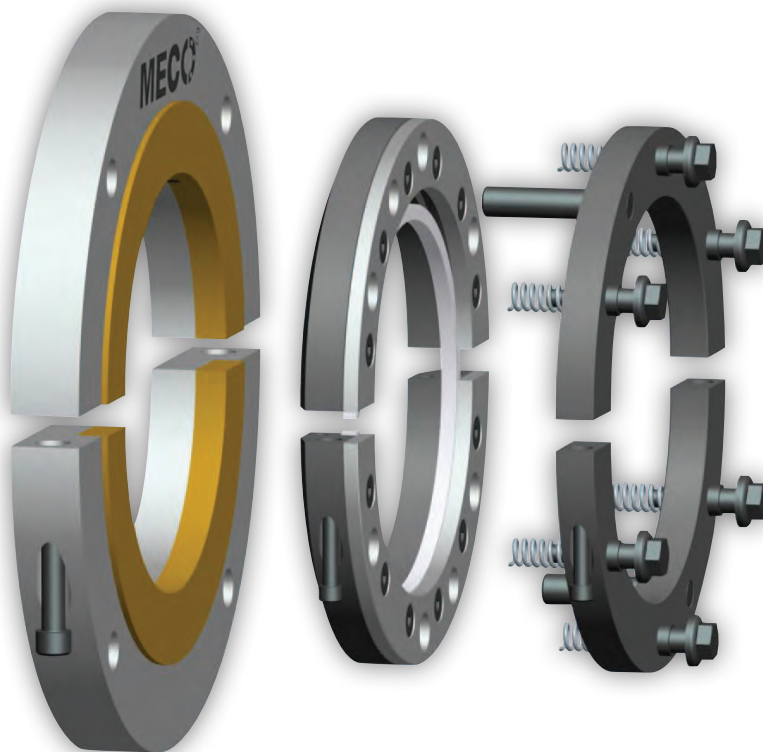

### WHEN ARE OFS TYPE-1 SEALS THE BEST OPTION?

The OFS Type-1 split seal is ideal for top-entry agitators, crystallizers, dryers, pan mixers, blenders, hoppers and similar rotating equipment used in the petrochemical, plastics, metals, minerals and other process industries. The OFS Type-1 seal is used with top-entering and horizontal shafts. The seal has been used with crystallizers operating at cryogenic temperatures, and in an environment with saturated steam under full vacuum and relatively hot conditions. The seal is often used both to keep process materials inside the vessel and also to keep atmospheric oxygen from entering the vessel. The OFS Type-1 is used in the production of plastic resins and additives, paraxylene, solvent-based ink, VOC vapors and fumes, crystal sugar, industrial chemicals and industrial fermentation processes. Process improvements encompass product and atmosphere containment, product purity, batch time reduction and consistency between batches, extended mean-time-to-repair (MTR), and only two to four hours of installation time once the equipment is prepared. The fully-split assemblies meet chemical compatibility and materials of construction challenges.

## MECO ENGINEERED SHAFT SEALS

Manufactured Since 1984 by:



216 Bay Point Road, Georgetown ME 04548 USA  
Phone 1 207 371 2210 • Toll-free in North America 1 800 526 8800 • Fax 1 207 371 2169  
www.mecoseal.com • Email sales@mecoseal.com  
© 2012 Woodex Bearing Company, Inc. All rights reserved

*The seal is often used both to keep process materials inside the vessel and also to keep atmospheric oxygen from entering the vessel.*

## HOW DOES THE OFS TYPE-1 SEAL WORK?

The OFS Type-1 seal replaces stuffing boxes, lip seal housings, hard-face mechanical seals, elastomer-driven seals and unsplit seals. The split seal housing is fitted to your equipment, complete with a split, bearing-grade, synthetic stationary seal face. Typically, the rotary seal face is made from hardened, stainless steel, positioned at a right angle to the shaft and is maintained in contact with the stationary seal face. Sealing along the shaft is accomplished with a static ring of braided packing or a square elastomer, contained within the inner diameter of the rotating seal face. The rotary seal face is turned by drive pins, fixed to a drive collar which is locked to the shaft. External springs & actuators are attached to the drive collar to load the rotary seal face. The seal designer predetermines the spring calibration, based on application parameters.



**2" OFS TYPE-1 SEAL INSTALLED ON A TOP-ENTRY AGITATOR CONTAINING VOCs AND MOLTEN PLASTIC RESIN**

## HOW IS THE OFS TYPE-1 MAINTAINED?

Although the external parts of the OFS Type-1 split seal are easily viewed for a quick visual inspection, when installed on top of a 30-foot agitator or behind a shroud, they become out-of-sight, out-of-mind and can be forgotten. As such, the seal rarely receives preventative maintenance, but continues performing as intended.

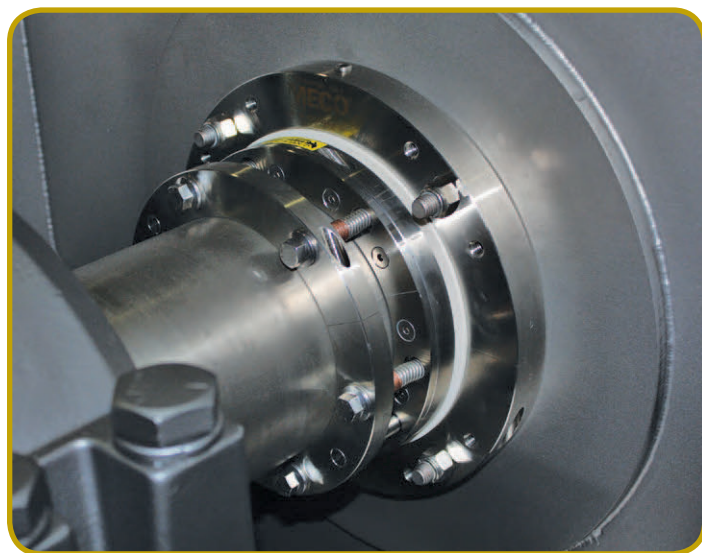

**7" OFS TYPE-1 SEAL INSTALLED ON A HORIZONTAL BLENDER CONTAINING VARIOUS GRADES OF PLASTIC RESINS**

However, to maximize the mean-time-to-repair (MTR), the seal is easily disassembled for inspection and resetting, as well as replacing any exposed O-rings or packing along with a general wipe down to remove any debris. By loosening the spring actuators and drive collar, the parts may be pulled back for inspection and resetting. Reassembly sets the seal face closing force to original values, accounting for any seal face wear and resetting the seal to a slower wear rate, maximizing the MTR.

## WHAT SIZES ARE AVAILABLE?

Dimensions will vary according to each application, but typical spatial dimensions with respect to the shaft diameter are shown in the illustration on the back page. The seals

are not forced to fit your equipment but designed with your equipment in the forefront. The OFS Type-1 seals are not re-designed from pump seal applications. They are readily designed to fit most mounting arrangements specified by OEMs and are designer-friendly, allowing MECO engineers to fit most existing process equipment "as is." OFS Type-1 seals are built utilizing either S.A.E or metric dimensions and fasteners.

# MECO OFS TYPE-1

## WHAT CONSTRUCTION IS AVAILABLE?

The OFS Type-1 seal components are designed fully-split and to install within your spatial constraints. They follow MECO's exacting standards of seamless fit and finish. Standard configuration uses a hardened stainless steel rotary seal face. The stationary seal face is selected from one of our MECO 3000 series of bearing-grade, PTFE-based blends. We have several polymeric materials to select from to match the needs of your application. The static seal component in contact with the shaft may be made of a braided packing or an elastomeric material. The drive assembly is made of stainless steel. The housing is either aluminum or stainless steel. MECO seals may be fabricated from a wide variety of suitable materials. This offers great flexibility to meet the demands of your application.

Additional seal features may be considered. In some instances, fitting the stuffing box with a steady bearing or packing can reduce runout. In some applications a barrier ring, mounted into the back of the seal housing, may help to maximize MTR. An optional port, entering in front of the stationary seal face, is a feature requested for some applications. The port provides a way to introduce an inert gas blanket or an air sweep in front of the seal and into the process vessel. Additionally, the port may be used to attach a pressure indicator for monitoring process pressure trends.

## HOW DOES THE OFS TYPE-1 SEAL TO THE EQUIPMENT?

MECO offers a few options to consider during your application review. You may have specific details for matching to your profile. O-rings, flat gaskets & bedding compounds are typical static sealing options available between the OFS Type-1 seal housing and the mounting surface on your equipment. Jacking screws are an enhancement that help to mount the OFS Type-1 seal's housing perpendicular to the shaft and control flatness of the stationary seal face. What does your mounting surface and shafting look like? We'll offer a few options to consider during your application review.



**3.5" OFS Type-1** INSTALLED ON A TOP-ENTRY AGITATOR CONTAINING VOLATILE ORGANIC COMPOUNDS (VOCs).



**TWO 5" OFS Type-1** SPLIT SEALS INSTALLED ON A HORIZONTAL PADDLE MIXER CONTAINING FINE MINERALS

# OFS TYPE-1 TYPICAL DIMENSIONS

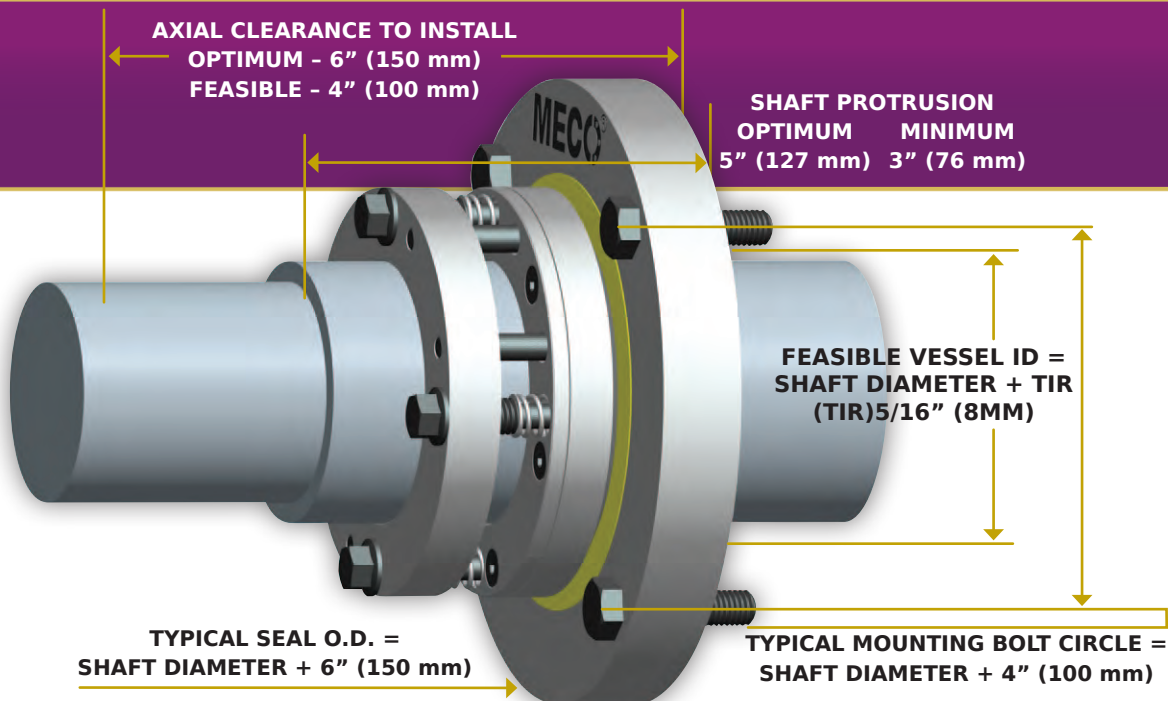

## Mechanical Capabilities

<b>Temperature</b>	-60° to 500° F (-50° to 260° C)
<b>Pressure</b>	Vacuum to 5 psig (35 kPa)
<b>Shaft Speed</b>	Up to 250 RPM
<b>Total Indicator Runout (TIR)</b>	5/16" (8mm) standard; greater runout can be accommodated
<b>Repeated Axial Shaft Motion</b>	1/64" (0.4mm)
<b>Thermal Shaft Growth</b>	1/8" (3mm) typical; actual limits are set by physical space and application parameters

*Results may vary with operating conditions - please call for discussion.*



*MECO's design staff or your local distributor can help tailor the OFS Type-1 to your individual needs.*

Below are a few examples of other **MECO** seal models.

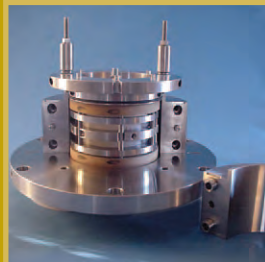

**EP Model**

- Reactor Vessels
- Dryers
- Extruders



**AH Model**

- Blenders
- Screw Conveyors
- Tight Spaces



**HC Model**

- Standard CEMA Seals not using a gas purge



**HB Model**

- Standard Seals for C.E.M.A. and Metric Screw Conveyors



**EA Model**

- Abrasive Slurries
- Adjustable on-the-Fly
- Large Diameters

**Distributed by:**



All MECO Seals

