



SEAL APPLICATION DATA SHEET

Woodex Bearing Co. Inc. • Georgetown, Maine USA 04548
(800) 526-8800 • (207) 371-2210 • FAX: (207) 371-2169
sales@woodex-meco.com • www.woodex-meco.com

PHOTOS AND DRAWINGS SENT VIA E-MAIL ARE VERY HELPFUL!

CONTACT INFORMATION:

Submitted By: _____ Date: _____
 Company Name: _____
 Street Address: _____
 City: _____ State/Province: _____ Postal Code & Country: _____
 Telephone #: _____ Email: _____
 How did you hear about us? _____

MACHINE INFORMATION:

Type of Machine (Mixer, Blender, Conveyor, etc.): _____
 Machine Manufacturer: _____
 Shaft Diameter: _____ RPM: _____ Condition of the Shaft: _____
 Vessel Opening Diameter: _____ Mounting Bolt Pattern: _____ Circle Square
 Bolts or Studs: _____ Size: _____ Qty: _____
 Shaft Position: Horizontal Bottom Entry Top Entry Inclined Degrees of Inclination: _____
 Purging Possible: Yes No Medium: N2 Air Water Other Seal Type: Split Unsplit
 Existing Stuffing Box: Yes No Bore Diameter: _____ Bore Depth: _____ Box OD: _____

CLEARANCE AROUND THE SHAFT:

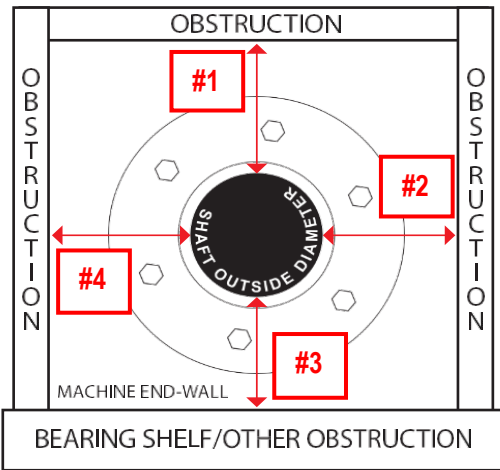

Dimension #1: _____
 Dimension #2: _____
 Dimension #3: _____
 Dimension #4: _____
 Dimension #5: _____

CLEARANCE ALONG THE SHAFT:

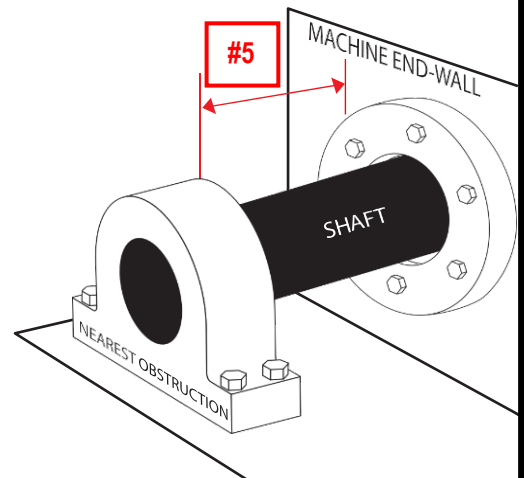

PROCESS INFORMATION:

Product(s) Handled: _____
 Temp Range: _____ - _____ F C Pressure Range (Gauge): _____ - _____ psi kPa
 Describe Thermal Cycle: _____ Describe Pressure Cycle: _____
 Duty Cycle: _____ Toxic / Corrosive Yes No
 Product State: Dry Moist Liquid Slurry Paste Particle Size: _____ Food Grade? Yes No
 Explosive: Yes No If Yes, Explain: _____
 Additional Notes: _____